

# TH

## 螺絲式濾心機 (5~7 支裝) Eye Bolt Type Filter Cartridge Housing (5-7Rounds)



設計壓力 Design P.	15 kgf/cm <sup>2</sup> 225 psi	最大操作壓力 Max Operating P.	15 kgf/cm <sup>2</sup> 225 psi
設計溫度 Design T.	100°C	操作溫度 Operating T.	75°C
選購配件 Accessory	各式濾芯 Cartridges		



TH	7	2	4	F	2	10K	E	EA
產品型號 Model	濾心支數 No. of Rounds	濾心長度 Length	產品材質 Material	濾心接頭 Adapters	進出口尺寸 Inlet & Outlet Size	進出口規格 Inlet & Outlet Type	O 環材質 O-ring	外 / 內表面處理 Exterior / Interior Surface Finishing
	5 6 7	1-10" 2-20" 3-30" 4-40"	4-304 6-316 6L-316L	F-DOE 5-222 7-226	21-1/2" 43-3/4" 1-1" 121-1-1/2" 2-2" 221-2-1/2" 3-3" 4-4"	150P-ANSI 10K-JIS PN10-DIN C-CLAMP PF-PTF NF-NPTF PM-PTM NM-NPTM	E-EPDM N-NBR V-VITON S-SILICON TS-TEFLON+SILICON	A- 酸洗 ACID-Washing E- 電解 Electrolyze P- 拋光 Polishing S- 噴砂 Sand Blasting

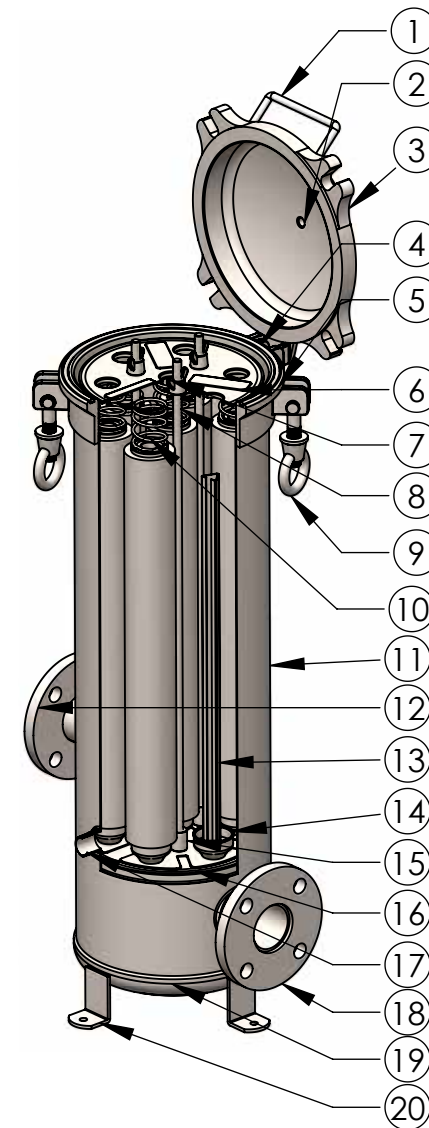

No.	名稱	Description
1	把手	Handle
2	排氣口	Vent
3	上蓋	Top cover
4	O-RING	O-ring
5	桶唇	Shell flange
6	壓板	Pressure plate
7	壓板螺母	Nut
8	雙頭牙條	Center post
9	單眼螺絲組	Eye bolt
10	彈簧組	Springs
11	桶體	Shell
12	入水口	Port Inlet
13	濾心角條	Cartridge post
14	杯座	Pedestal
15	集水板螺母	Nut
16	集水板	Cartridge Seat plate
17	排放口	Drain
18	出水口	Port Outlet
19	端板	Bottom cover
20	L 型腳架	Support leg

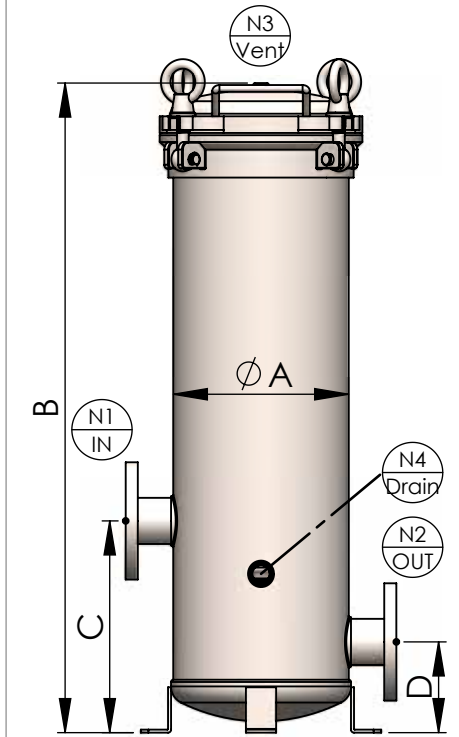
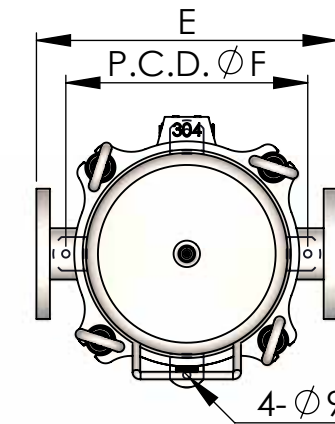

型式 Model	濾心長度 Length	A m/m	B m/m	C m/m	D m/m	E m/m	F(PCD) m/m	流量 M <sup>3</sup> /Hr	流量(加侖) GPM	重量 Weight	容量 Volume
TH5~7	10"	Ø232	605	280	120	358	Ø288	5~7	25~35	30kg	23L
TH5~7	20"	Ø232	860	280	120	358	Ø288	10~14	50~70	35kg	34L
TH5~7	30"	Ø232	1115	280	120	358	Ø288	15~21	75~105	40kg	45L
TH5~7	40"	Ø232	1370	280	120	358	Ø288	20~28	100~140	46kg	55L