

KRQ

多袋式快拆彈簧式袋濾機 Quick Open Type Multi Filter Bag Housing



設計壓力 Design P.	10 kgf/cm ² 150 psi	最大操作壓力 Max Operating P.	10 kgf/cm ² 150 psi
設計溫度 Design T.	100°C	操作溫度 Operating T.	75°C

選購配件 各式濾袋、壓袋器、濾袋撐開架、金屬浮球
Accessory Filter Bag, Bag Pressing, Bag Bracket, Metal float ball



KRQ	4	2	4	SB	4	150P	E	EA
產品型號 Model	濾袋數量 Qty of Bags	濾袋規格 Bag Size	產品材質 Material	進出口方向 Inlet & Outlet	進出口尺寸 Inlet & Outlet Size	進出口規格 Inlet & Outlet Type	O 環材質 O-ring	外 / 內表面處理 Exterior / Interior Surface Finishing
	2~8	1-Bag No.1 2-Bag No.2	4-304 6-316 6L-316L	SS- 側進側出 Side In & Side Out SB- 側進底出 Side In & Botton Out BB- 底進底出 Botton In & Botton Out	2-2" 221-2-1/2" 3-3" 4-4" 5-5" 6-6" 8-8"	150P-ANSI 10K-JIS PN10-DIN C-CLAMP PF-PTF NF-NPTF PM-PTM NM-NPTM	E-EPDM N-NBR V-VITON S-SILICON	A- 酸洗 ACID-Washing E- 電解 Electrolyze P- 拋光 Polishing S- 噴砂 Sand Blasting

No.	名稱	Description
1	上蓋	Top cover
2	上蓋唇	Top cover flange
3	排氣口	Vent
4	掀蓋組	Raises cover units
5	O 型環	O-ring
6	束環	Clamp
7	桶唇	Shell flange
8	濾袋座	Filter bag plate
9	金屬內網	Basket
10	轉盤	Turntable
11	桶體	Shell
12	端板	Bottom cover
13	排放口	Drain
14	出 / 入水口	Port (Inlet/outlet)
15	腳架	Support Leg

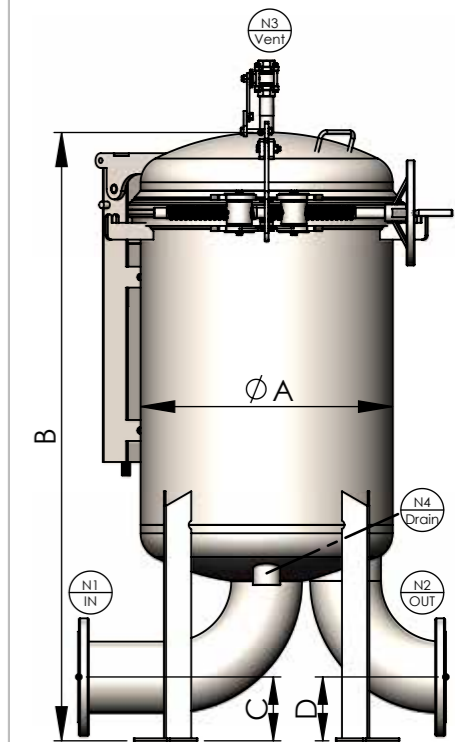
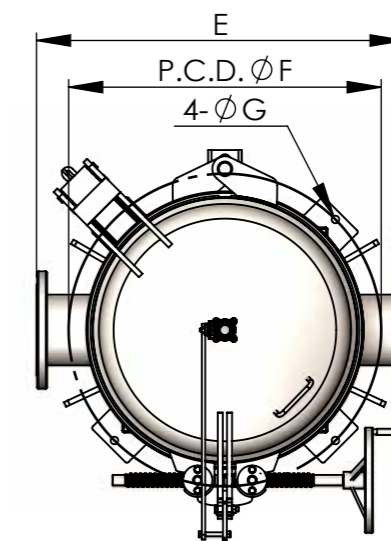
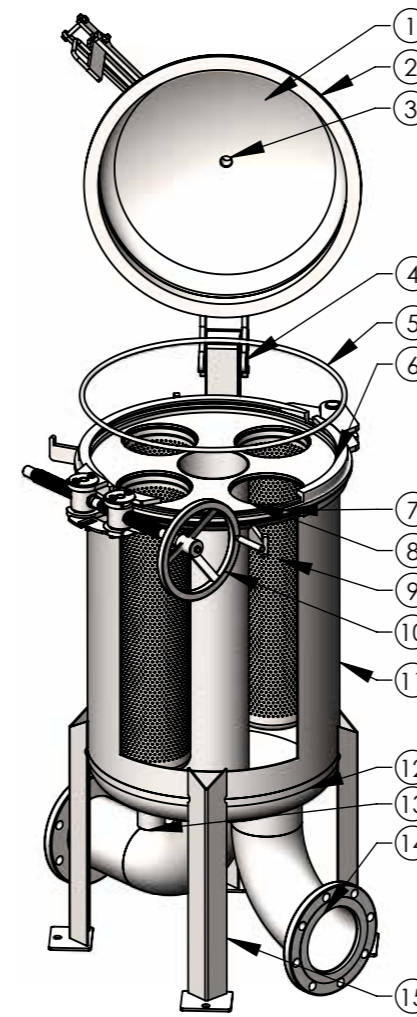

型式 Model	Inlet and Outlet Size	Qty of Bags	A m/m	B m/m	C m/m	D m/m	E m/m	F(PCD) m/m	G m/m	流量 M ³ /Hr	重量 Weight	容量 Volume
KRQ2	3F	2	Ø406	1192	108	108	584	Ø516	Ø14	90	97kg	116L
KRQ2	4F	2	Ø406	1248	127	127	660	Ø516	Ø14	90	102kg	117L
KRQ3	3F	3	Ø508	1231	108	108	686	Ø618	Ø14	135	125kg	188L
KRQ3	4F	3	Ø508	1287	127	127	724	Ø618	Ø14	135	130kg	189L
KRQ4	3F	4	Ø560	1253	108	108	686	Ø704	Ø14	180	161kg	244L
KRQ4	4F	4	Ø560	1309	127	127	737	Ø704	Ø14	180	169kg	245L
KRQ4	6F	4	Ø600	1423	152	152	876	Ø744	Ø14	180	206kg	279L
KRQ5	3F	5	Ø560	1253	108	108	698	Ø704	Ø14	225	160kg	244L
KRQ5	4F	5	Ø560	1309	127	127	737	Ø704	Ø14	225	165kg	278L
KRQ5	6F	5	Ø600	1423	152	152	876	Ø744	Ø18	225	206kg	246L
KRQ6	3F	6	Ø600	1269	108	108	724	Ø744	Ø18	270	198kg	277L
KRQ6	4F	6	Ø600	1325	127	127	763	Ø744	Ø18	270	202kg	278L
KRQ6	6F	6	Ø600	1423	152	152	876	Ø744	Ø18	270	206kg	279L
KRQ8	3F	8	Ø762	1343	108	108	813	Ø962	Ø19	315	430kg	488L
KRQ8	4F	8	Ø762	1399	127	127	864	Ø962	Ø19	315	440kg	489L
KRQ8	6F	8	Ø762	1498	152	152	927	Ø962	Ø19	315	450kg	491L
KRQ8	8F	8	Ø762	1604	184	184	1047	Ø962	Ø19	315	460kg	493L