

TA

單支式濾心機 (束環式) Clamp Type Single Filter Cartridge Housing

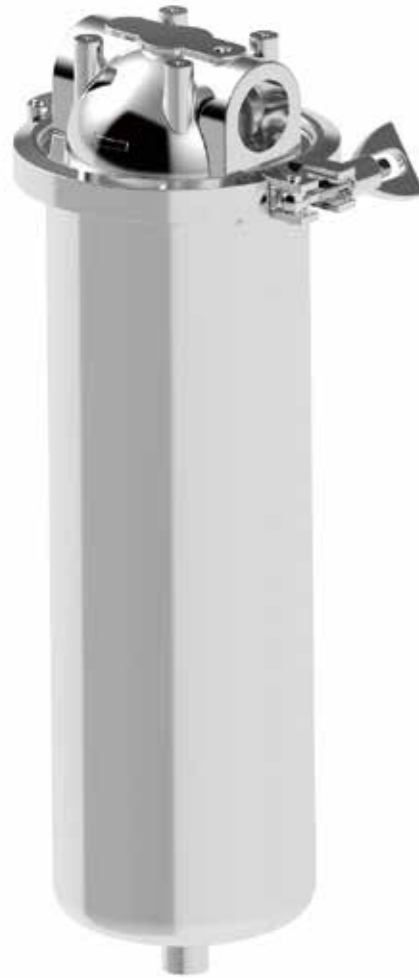

設計壓力 Design P.	10 kgf/cm ² 150 psi	最大操作壓力 Max Operating P.	10 kgf/cm ² 150 psi
設計溫度 Design T.	100°C	操作溫度 Operating T.	75°C
選購配件 Accessory	各式濾芯、吊片 Cartridges、Lifting Lug		



TA	1	4	F	1	PF	E	PA
產品型號 Model	濾心長度 Length	產品材質 Material	濾心接頭 Adapters	進出口尺寸 Inlet & Outlet Size	進出口規格 Inlet & Outlet Type	O 環材質 O-ring	外 / 內表面處理 Exterior / Interior Surface Finishing
	1-10" 2-20" 3-30"	4-304 6-316 6L-316L	F-DOE 5-222 7-226	43-3/4" 1-1"	150P-ANSI 10K-JIS PN10-DIN C-CLAMP PF-PTF NF-NPTF	E-EPDM N-NBR V-VITON S-SILICON	A- 酸洗 ACID-Washing E- 電解 Electrolyze P- 拋光 Polishing

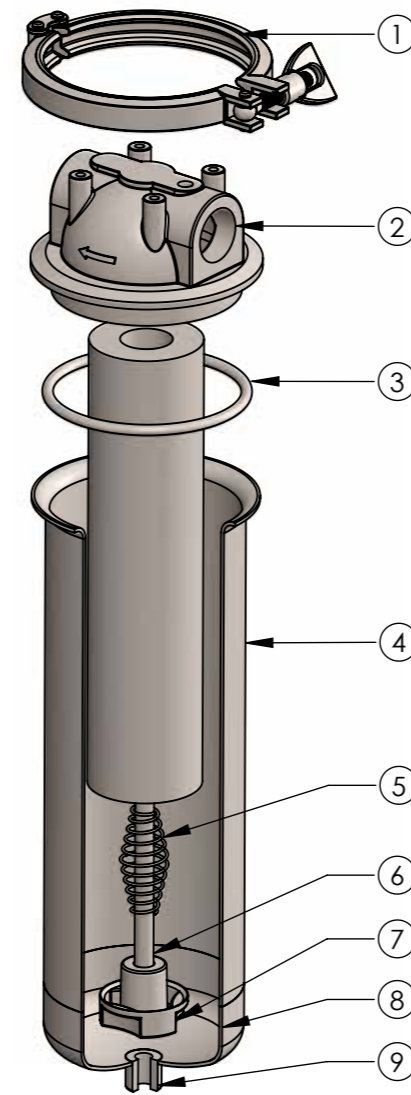

No.	名稱	Description
1	束環	Clamp
2	集水頭	Head
3	O 型環	O-ring
4	桶體	Shell
5	彈簧	Springs
6	濾心螺桿	Screw rod
7	濾心鎖螺	Nut
8	端板	Bottom cover
9	排放口	Drain

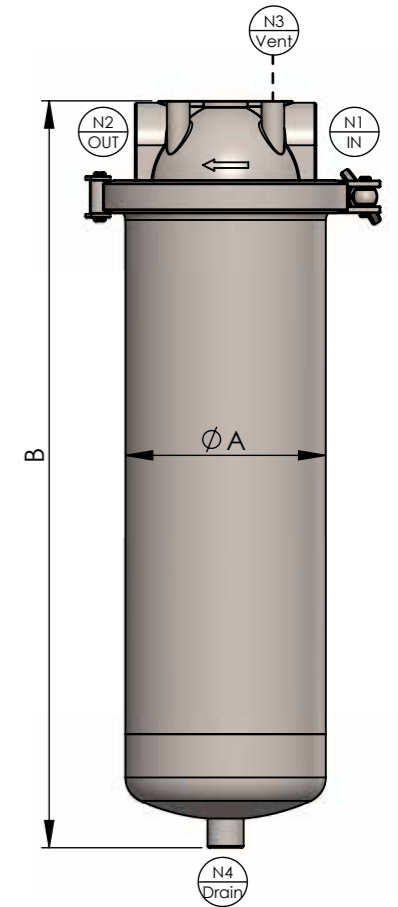
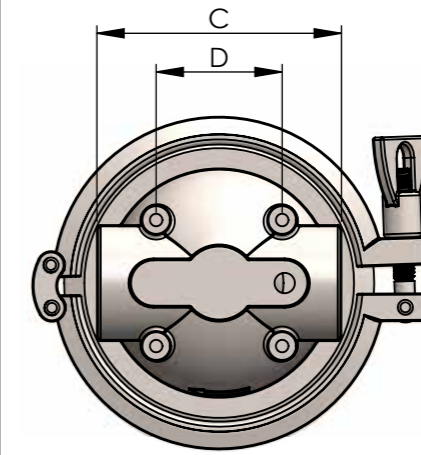

型式 Model	濾心長度 Length	A m/m	B m/m	C m/m	D m/m	流量 M ³ /Hr	流量(加侖) GPM	重量 Weight
TA1	10"	Ø106	395	97	50	1	5	4kg
TA2	20"	Ø106	645	97	50	2	10	5.5kg
TA3	30"	Ø106	895	97	50	3	15	7kg