

TR

多支式螺絲彈簧式濾心機 Spring Lid Type Multi Filter Cartridge Housing



設計壓力 Design P.	10 kgf/cm ² 150 psi	最大操作壓力 Max Operating P.	10 kgf/cm ² 150 psi
設計溫度 Design T.	100°C	操作溫度 Operating T.	75°C

選購配件 各式濾芯、中間隔板
Accessory Cartridges、Partition



TR	20	3	4	F	3	10K	E	EA
產品型號 Model	濾心支數 No. of Rounds	濾心長度 Length	產品材質 Material	濾心接頭 Adapters	進出口尺寸 Inlet & Outlet Size	進出口規格 Inlet & Outlet Type	O 環材質 O-ring	外 / 內表面處理 Exterior / Interior Surface Finishing
	13-82	3-30" 4-40"	4-304 6-316 6L-316L	F-DOE 5-222 7-226	2-2" 221-2-1/2" 3-3" 4-4" 5-5" 6-6"	150P-ANSI 10K-JIS PN10-DIN C-CLAMP PF-PTF NF-NPTF PM-PTM NM-NPTM	E-EPDM N-NBR V-VITON S-SILICON TS-TEFLON+SILICON	A- 酸洗 ACID-Washing E- 電解 Electrolyze P- 拋光 Polishing S- 噴砂 Sand Blasting

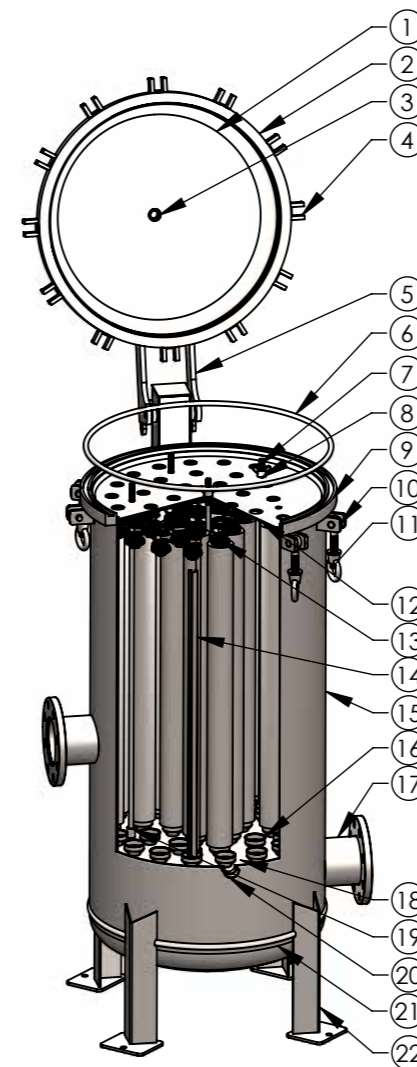

No.	名稱	Description
1	上蓋	Top cover
2	上蓋唇	Top cover flange
3	排氣口	Vent
4	環首螺母座	Eye nut socket
5	掀蓋組	Raises cover units
6	O-RING	O-ring
7	雙頭牙條	Threaded Rod
8	壓板螺母	Nut
9	桶唇	Shell flange
10	單眼螺絲座	Eye bolt socket
11	單眼螺絲組	Eye bolt
12	壓板	Pressure plate
13	彈簧組	Springs
14	濾心角條	Cartridge post
15	桶體	Shell
16	杯座	Pedestal

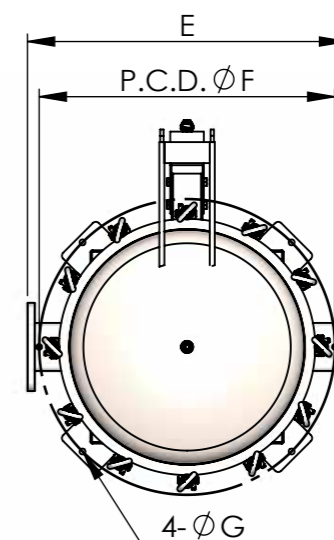

No.	名稱	Description
17	出入口	Port(Outlet/Inlet)
18	集水板	Cartridge support plate
19	集水板螺母	Nut
20	排放口	Drain
21	端板	Bottom cover
22	腳架	Support leg

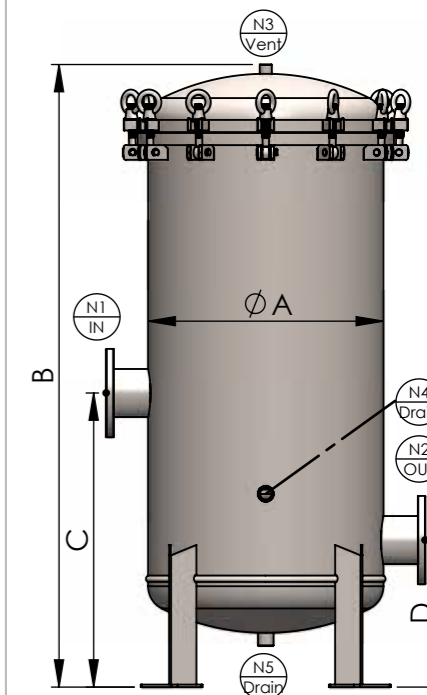

型式 Model	濾心長度 Length	N1/N2	N4/N5	A m/m	B m/m	C m/m	D m/m	E m/m	F(PCD) m/m	G m/m	流量 M ³ /Hr	流量(加侖) GPM	重量 Weight	容量 Volume
TR13~20	30"	2"~4"F	1"PT-F	Ø406	1451	700	350	606	Ø516	Ø14	39~60	195~300	105kg	165L
TR13~20	40"	2"~4"F	1"PT-F	Ø406	1701	700	350	606	Ø516	Ø14	52~80	260~400	125kg	198L
TR21~28	30"	3"~4"F	1"PT-F	Ø508	1470	700	350	708	Ø618	Ø14	63~84	315~420	150kg	327L
TR21~28	40"	3"~4"F	1"PT-F	Ø508	1720	700	350	708	Ø618	Ø14	84~112	420~560	195kg	389L
TR29~40	30"	3"~4"F	1"PT-F	Ø560	1481	700	350	760	Ø704	Ø18	87~108	435~540	190kg	327L
TR29~40	40"	3"~4"F	1"PT-F	Ø560	1731	700	350	760	Ø704	Ø18	116~138	580~720	225kg	389L
TR41~52	30"	4"~6"F	1"PT-F	Ø600	1569	800	400	800	Ø744	Ø18	111~138	555~690	200kg	401L
TR41~52	40"	4"~6"F	1"PT-F	Ø600	1819	800	400	800	Ø744	Ø18	148~184	740~920	230kg	460L
TR53~57	30"	4"~6"F	1"PT-F	Ø650	1638	850	450	850	Ø794	Ø18	141~168	705~840	242kg	484L
TR53~57	40"	4"~6"F	1"PT-F	Ø650	1908	850	450	850	Ø794	Ø18	188~224	940~1120	280kg	567L
TR58~82	30"	4"~6"F	1 1/2"PT-F	Ø762	1711	950	500	962	Ø962	Ø19	171~243	855~1215	365kg	665L
TR58~82	40"	4"~6"F	1 1/2"PT-F	Ø762	1961	950	500	962	Ø962	Ø19	228~324	1140~1620	408kg	802L

T 系列

K 系列

F 系列

S 系列

R 系列

H 系列

L 系列

X 系列

過濾設備 · 壓力容器 · 管線設備 · 材料專業

OZTTER

www.oztter.com

19

OZTTER

18

OZTTER

www.oztter.com