

KH

單袋螺絲式濾袋機 (3~4 號) Eye Bolt Type Single Filter Bag Housing (Bag No.3~No.4)



設計壓力 Design P.	15 kgf/cm ² 225 psi	最大操作壓力 Max Operating P.	15 kgf/cm ² 225 psi
設計溫度 Design T.	100°C	操作溫度 Operating T.	75°C
選購配件 Accessory	各式濾袋、壓袋器、濾袋撐開架、金屬浮球 Filter Bag, Bag Pressing, Bag Bracket, Metal float ball		



KH	2	4	SB	2	10K	E	EA
產品型號 Model	濾袋規格 Bag Size	產品材質 Material	進出口方向 Inlet & Outlet	進出口尺寸 Inlet & Outlet Size	進出口規格 Inlet & Outlet Type	O 環材質 O-ring	外 / 內表面處理 Exterior / Interior Surface Finishing
	3-Bag No.3 4-Bag No.4	4-304 6-316 6L-316L	SS- 側進側出 Side In& Side Out SB- 側進底出 Side In & Bottom Out	21-1/2" 43-3/4" 1-1" 121-1-1/2" 2-2" 221-2-1/2"	150P-ANSI 10K-JIS PN10-DIN C-CLAMP PF-PTF NF-NPTF PM-PTM NM-NPTM	E-EPDM N-NBR V-VITON S-SILICON TS-TEFLON+SILICON	A- 酸洗 ACID-Washing E- 電解 Electrolyze P- 拋光 Polishing S- 噴砂 Sand Blasting

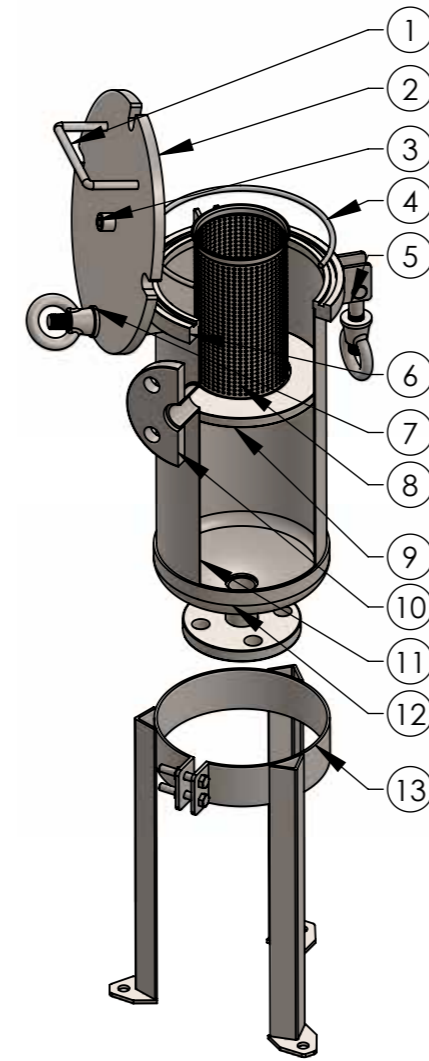

No.	名稱	Description
1	把手	Handle
2	上蓋	Top cover
3	排氣口	Vent
4	O 型環	O-ring
5	單眼螺絲座	Eye bolt socket
6	桶唇	Shell flange
7	單眼螺絲組	Eye bolt
8	金屬內網	Basket
9	濾袋座	Filter bag plate
10	出 / 入水口	Port(Outlet/Inlet)
11	桶體	Shell
12	端板	Bottom cover
13	活動腳架	Support leg

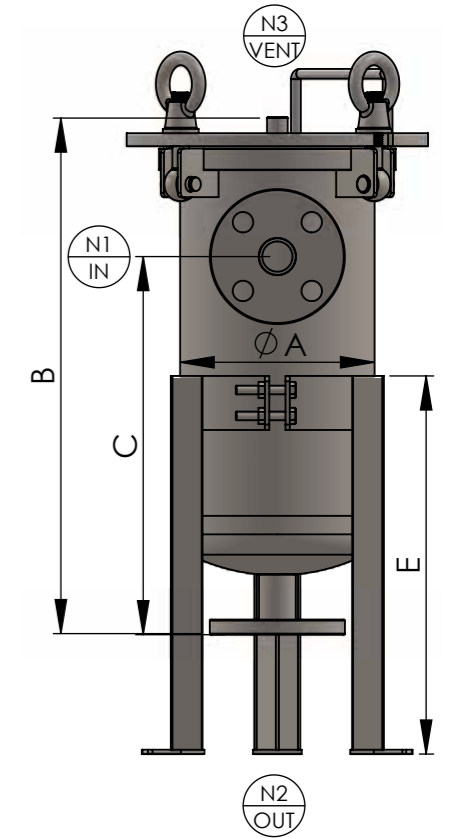
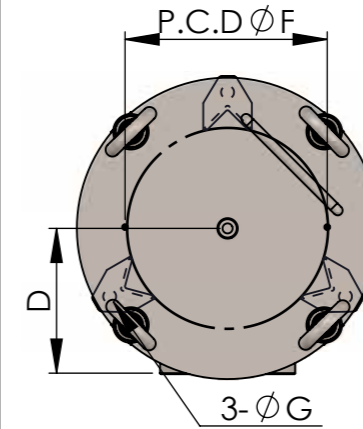

型式 Model	A m/m	B m/m	C m/m	D m/m	E m/m	F(PCD) m/m	G m/m	流量 M ³ /Hr	流量(加侖) GPM	重量 Weight	容量 Volume
KH3	Ø180	485	350	150	350	Ø252	Ø12	4.5	20	18kg	6.3L
KH4	Ø180	585	450	150	350	Ø252	Ø12	9	45	21kg	7.8L